



SC4ZTC

CE RoHS LVD RED

Features

- Apply to single color LED controller.
- Ultra sensitive color adjustment touch wheel.
- Each remote can match one or more receiver.
- AAAx2 battery powered.
- Operate with LED indicator light.

Technical Parameters

Input and Output	
Output signal	RF(2.4GHz)
Working voltage	3VDC(AAAx2)
Working current	< 5mA
Standby current	< 10µA
Standby time	1 year
Remote distance	30m(Barrier-free space)
Environment	
Operation temperature	Ta: -30°C ~ +55°C
IP rating	IP20

Safety and EMC	
EMC standard (EMC)	EN301 489,EN 62479
Safety standard(LVD)	EN60950
Radio Equipment(RED)	EN300 328
Certification	CE,EMC,LVD,RED
Weight	
Net weight	0.048kg
Gross weight	0.088kg

Mechanical Structures and Installations

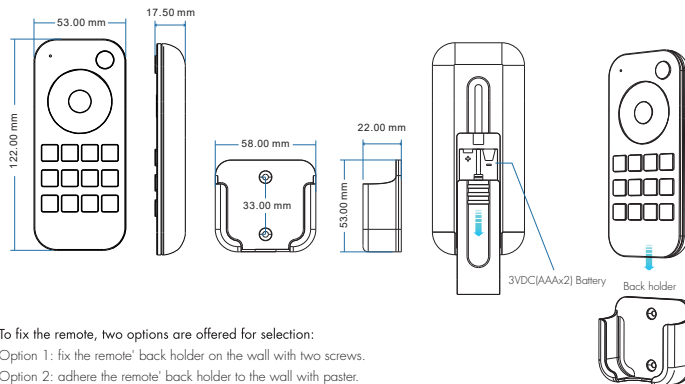

To fix the remote, two options are offered for selection:

- Option 1: fix the remote' back holder on the wall with two screws.
- Option 2: adhere the remote' back holder to the wall with pasteur.

Operation

- When turn on light, the indicator display blue. when turn off light, the indicator display red.
- When touch the color wheel, the indicator will display the same color.
- When press or touch operation is invalid (If the light is off), the indicator display red.
- To extend battery life, no touch or press key operation after a few seconds, the touch wheel will enter sleep state, you need press any key to make touch wheel quit sleep state.

Match Remote Control (two match ways)

End user can choose the suitable match/delete ways. Two options are offered for selection:

Use the controller's Match key

Match:
Short press match key, immediately press zone key of the remote.

The LED indicator fast flash a few times means match is successful.

Delete:
Press and hold match key for 5s to delete all match, The LED indicator fast flash a few times means all matched remotes were deleted.

Use Power Restart

Match:
Switch off the power, then switch on power again, immediately short press zone key 3 times on the remote. The light blinks 3 times means match is successful.

Delete:
Switch off the power, then switch on power again, immediately short press zone key 5 times on the remote. The light blinks 5 times means all matched remotes were deleted.

Key function

• SC4ZTC 4 zone dimming remote



 : Short press turn on/off all zone light.

 : Touch to change current zone brightness.

 : Short press select and turn on zone light, long press 2s turn off zone light. Short press multiple zone key fastly, will select multiple zone synchronously.

 : 25%, 50%, 75%, 100% brightness for current selected zone.

 : Short press recall the scene, long press 2s save current state into S1/2/3/4. the LED indicator display green when save OK. 4 zone recall or save synchronously.

Safety information

1. Read all instructions carefully before you begin this installation.
2. When installing battery, pay attention to the battery positive and negative polarity. A long time without the remote control, remove the battery. When remote distance becomes smaller and insensitive, replace the battery.
3. If no response from the receiver, please re-match the remote.
4. Gently handle remote, beware of falling.
5. For indoor and dry location use only.